

PUMPING ELEMENT MODEL :- 1RP / 2RP

Description

Pumping element for 1RP / 2RP with suction, delivery and spring loaded piston.

Oil immersed, Open execution,

Face mounting, fixed delivery. Bi-directional

Seven types of pumping elements, each having different pressure & displacement rating.

Odd number of elements results in smoother flow.



Section

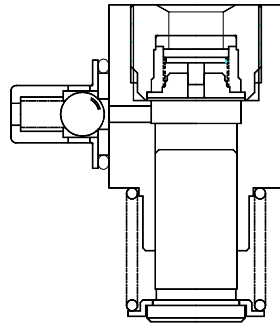

Hydraulic Symbol

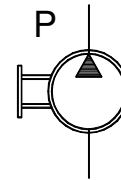

Unit dimensions

Dimensions in mm.

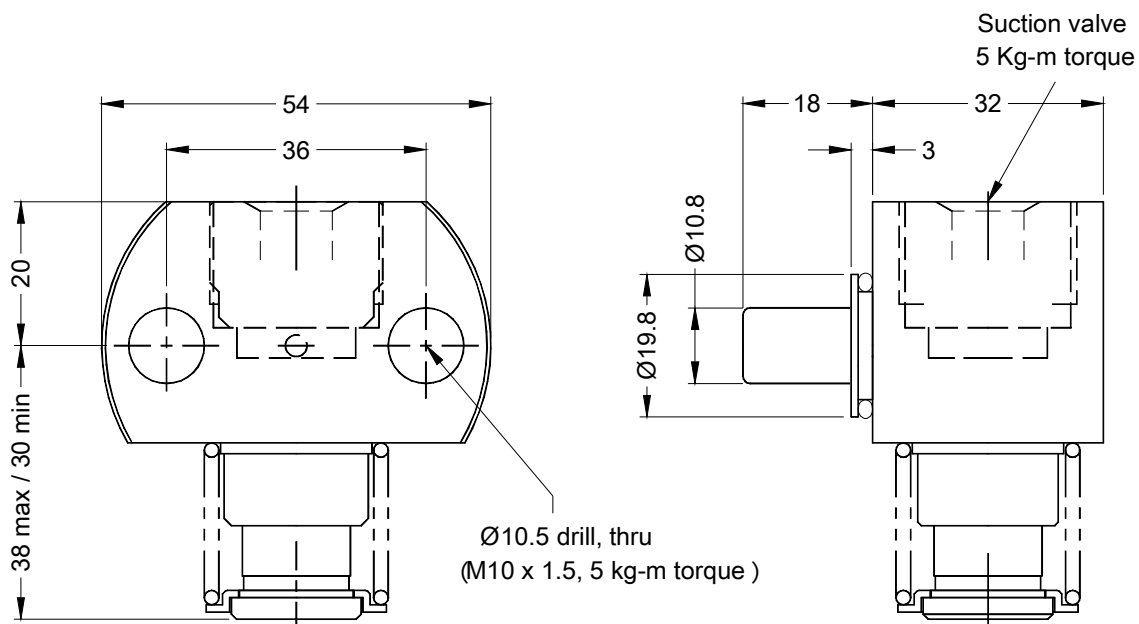
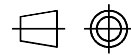

PUMPING ELEMENT MODEL :- 1RP / 2RP

Technical specifications

Construction	Pumping element for 1RP / 2RP
Design	Plunger type, Valve controlled.range
Mounting	Face mounting
Interface	Factory standard
Speed range	300 to 2000 rpm
Hydraulic medium	Mineral oil
Viscosity range	10 to 100 cSt.
Optimum viscosity range	16 to 32 cSt
Temperature range	-10 to +80 degree celcius (Do not exceed viscosity limits at extreme temperatures for efficient running of the pump)
Fluid cleanliness requirement	As per ISO code 16 / 13 or better
Performance	Refer Table in ordering code.
Mass0.4 kg

Ordering code

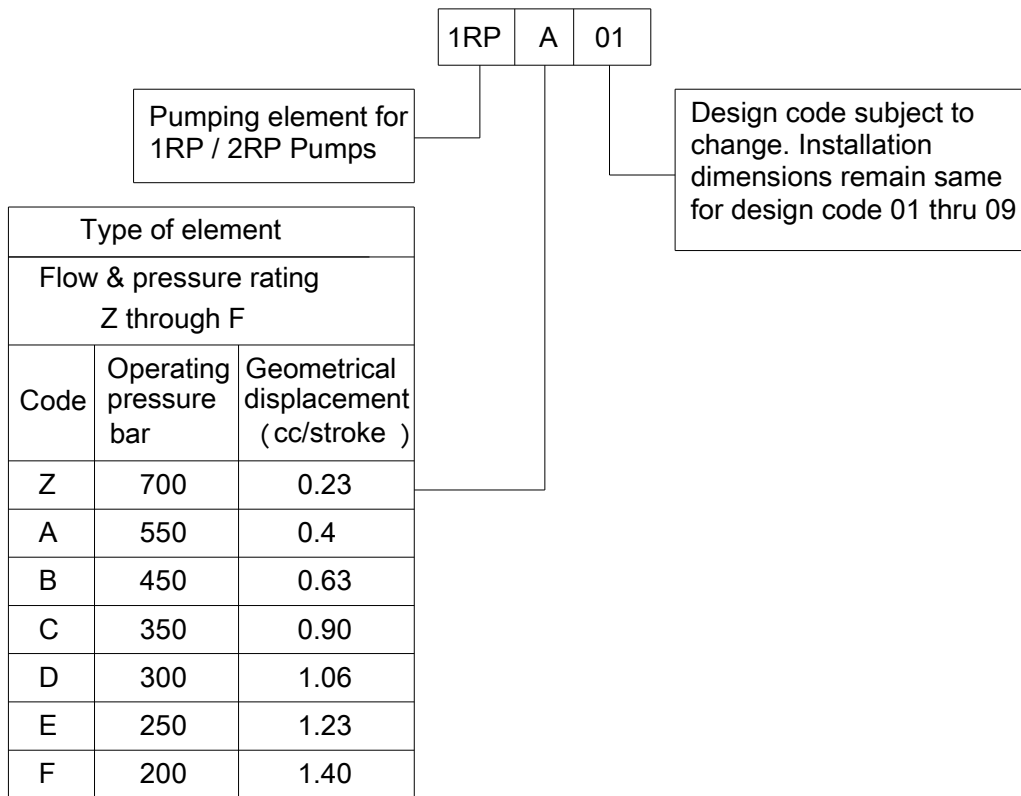

All rights reserved
subject to revision.

PRISM HYDRAULICS PVT. LTD.
B-23, Angol Indl. Estate,
Udyambag,
Belgaum - 590 008. INDIA.

Phone :- +91-(0831)-2443448
Fax :- +91-(0831)-4202340
E-mail :- prismhydraulics@gmail.com