

PRESSURE CONTROL UNIT MODEL : PCU 20-16

Description

Pressure Control Unit is designed to control double pumps of Hi-Low system.

Unloads low pressure pump when system pressure rises above the Unloader pressure.

Relieves the High pressure pump when system pressure reaches the Relief valve setting. Solenoid unloading facility is available as an option.

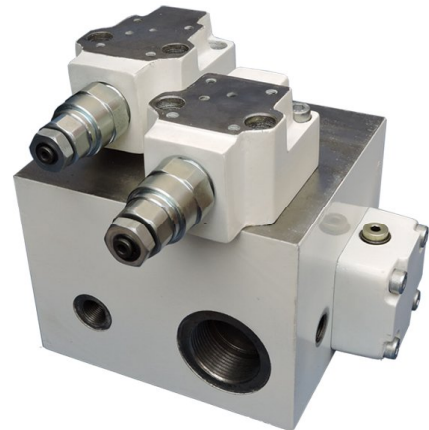

Hydraulic Symbol

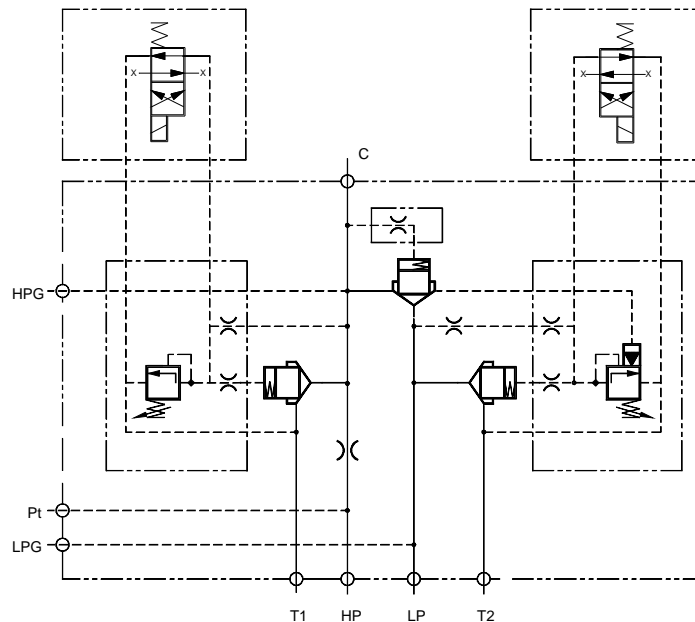

Connection details.

- HP ----- High pressure pump connection
- LP ----- Low pressure pump connection
- C ----- Out-let connection
- HPG ----- Gauge connection on high pressure pump line
- LPG ----- Gauge connection on low pressure pump line
- Pt ----- Pilot pressure connection (Optional)
- T1 ----- Tank connection of high pressure pump line
- T2 ----- Tank connection of low pressure pump line

PRESSURE CONTROL UNIT MODEL : PCU 20-16

Unit Dimensions

Dimensions in mm.

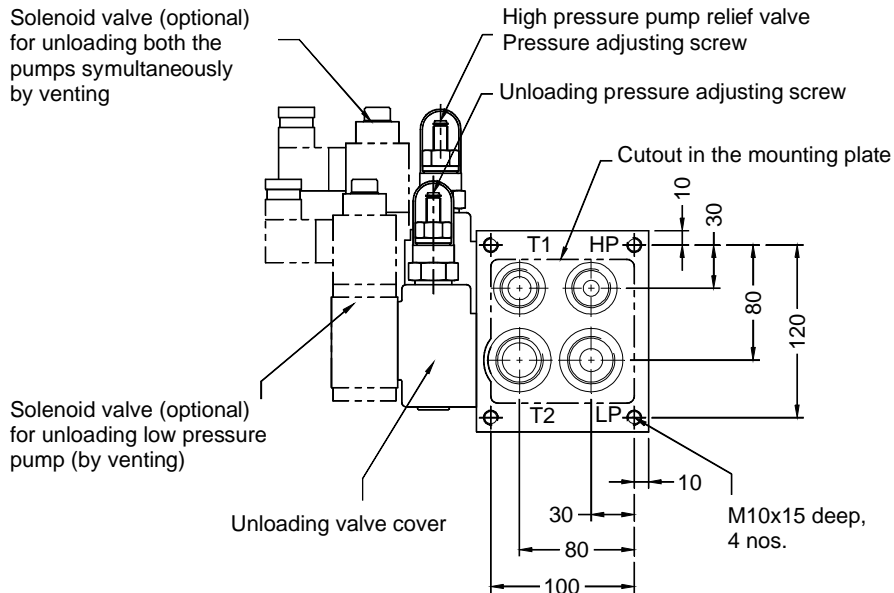
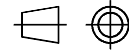

Port	Details
HP	G3/4
LP	G1
P	G1-1/4
Pt	G3/8
HPG	G1/4
LPG	G1/4
T1	G3/4
T2	G1

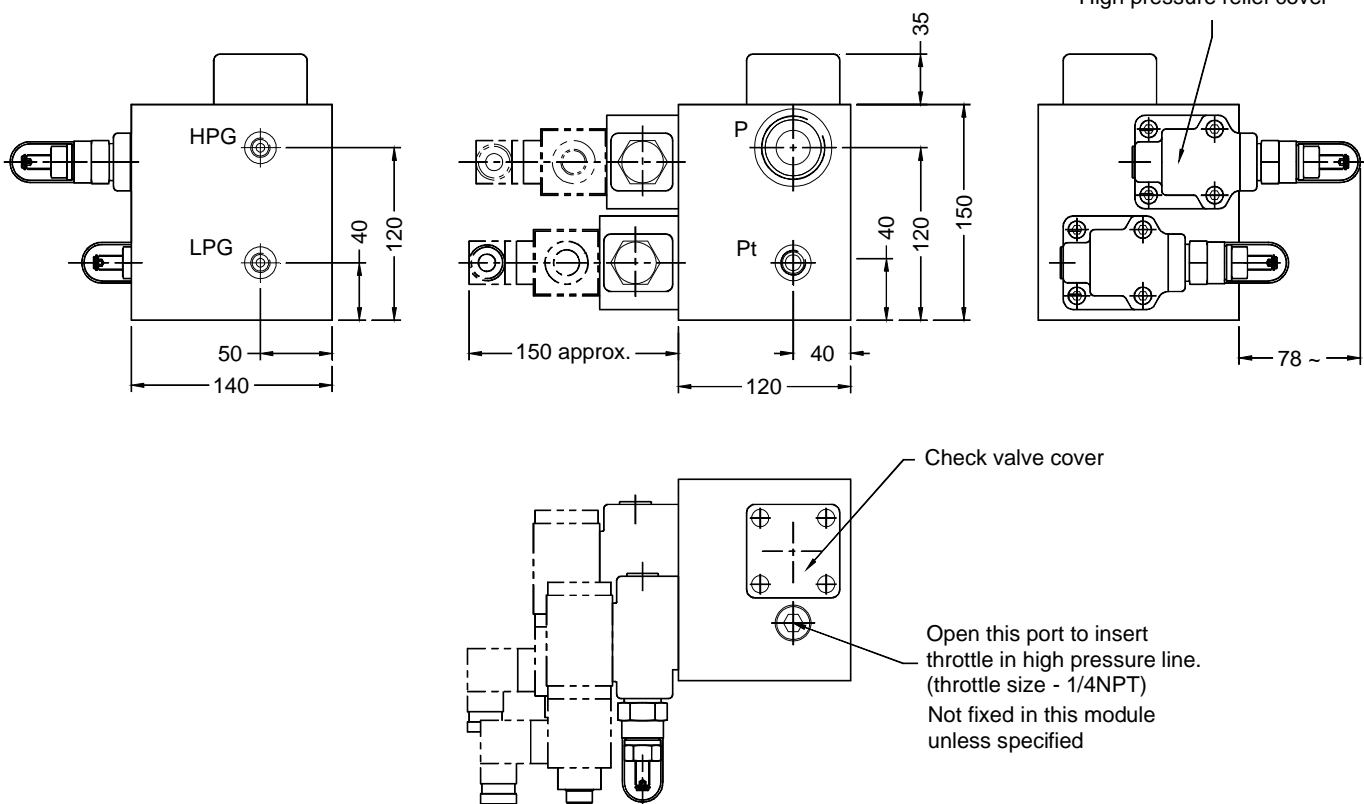

PRESSURE CONTROL UNIT MODEL : PCU 20-16

Technical Specification

Construction	Two stage poppet type high pressure relief valve. Two stage poppet type low pressure unloading valve. All valves fitted in the cavities machined as per DIN 24342
Mounting	Threaded body (Factory standard)
Mounting position	Optional.
Direction of flow	As per hydraulic symbol.
Operating pressure	For low pressure pump port 50 and 100 bar max. For high pressure pump port 100, 200,315 bar.
Hydraulic Medium	Mineral oil.
Viscosity range	10 cSt to 380 cSt.
Fluid temperature range	-20 °C to +70 °C
Fluid cleanliness requirement	As per ISO 16 / 13.
Flow handling capacity	High pressure ---- 100 l / min. Low pressure ---- 160 l / min.
Mass	14 kg. approx.

Ordering Code

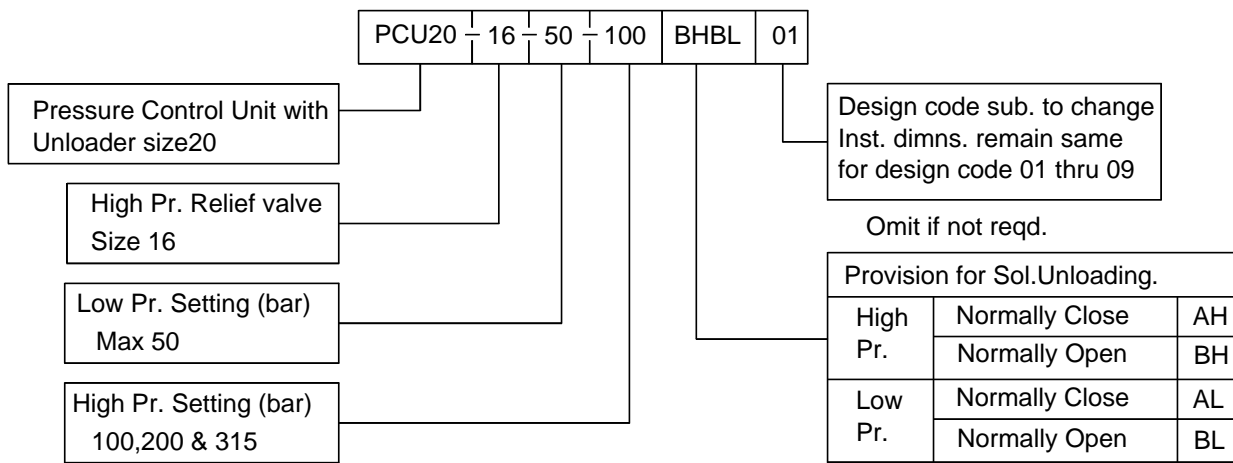

PRESSURE CONTROL UNIT MODEL : PCU 20-16

All rights reserved
subject to revision.

PRISM HYDRAULICS PVT. LTD.
B-23, Angol Indl Estate,
Udyambag,
Belgaum - 590 006. INDIA.

Phone :- +91-(0831)-2443448
Fax :- +91-(0831)-4202340
E-mail :- prismhydraulics@gmail.com